

Straight Bevel Gearboxes For Heavy Belt Conveyors

Type K1SH-100 and K1S-100 F

Manufacturer: Wolfgang Preinfalk GmbH

The gearboxes are dedicated for heavy belt conveyors with transferred power up to 500 kW at nominal speed 1470 r.p.m.

The gearboxes have an outlet for the brake wheel or for the equipment to prevent the reverse run.

The gearboxes are manufactured in the explosion-proof version.

Table of Transferred Power by Input Speed 1470 r.p.m.

Gear Ratio i	Transferred Power in kW											
	15 : 1	16 : 1	17 : 1	19 : 1	21 : 1	24 : 1	25 : 1	28 : 1	31 : 1	33 : 1	39 : 1	45 : 1
		110	110	110	110		110					

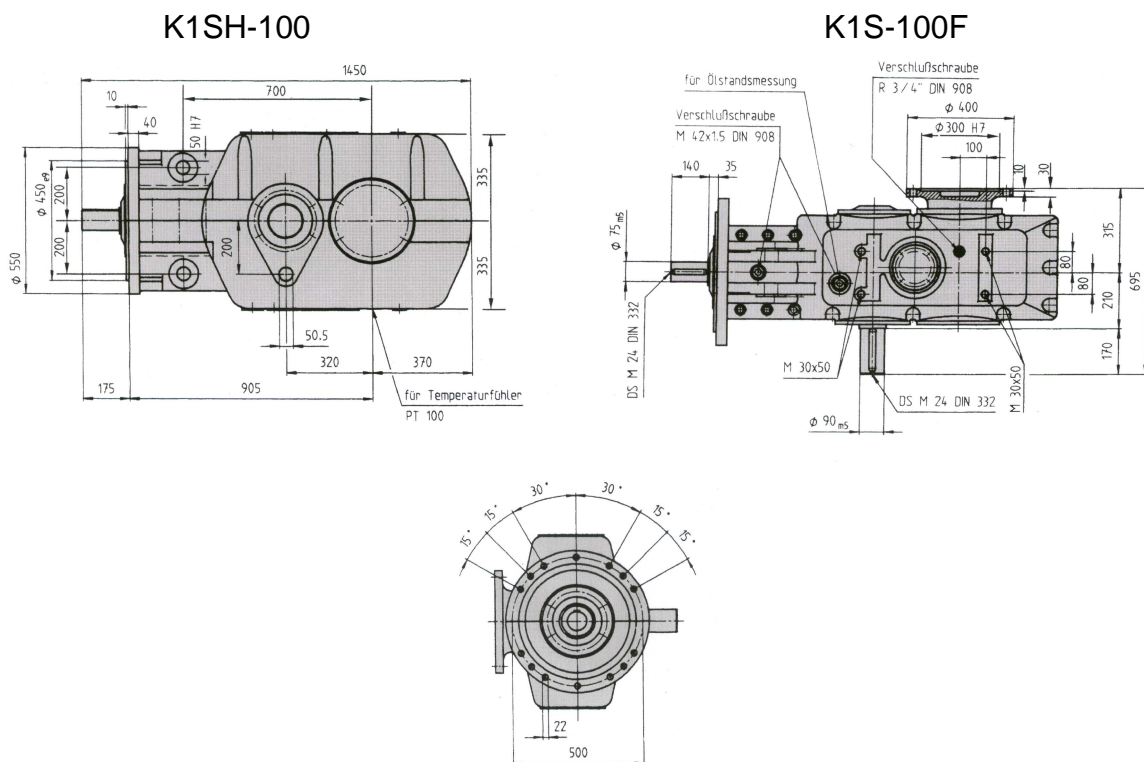

Technical Parameters:

Gear Ratio	Maximum Torsion Moment	Output Revolutions	Speed of Belt v=m/s by the drum diameter			
	Nm	r.p.m.	500	630	800	1000
12.5 : 1	714	116.8	3.06	3.86	4.89	6.11
14.8 : 1	714	99.2	2.60	3.27	4.16	5.20
16 : 1	714	90.5	2.37	2.99	3.79	4.74
17 : 1	714	85.6	2.25	2.83	3.59	4.48
18 : 1	714	80.9	2.12	2.67	3.39	4.42
19 : 1	714	76.4	2.00	2.50	3.20	4.00
21 : 1	714	68.2	1.79	2.25	2.86	3.57
22.5 : 1	714	65.4	1.71	2.16	2.74	3.42
25 : 1	714	58.9	1.54	1.94	2.47	3.08