

Straight Bevel Gearboxes For Heavy Belt Conveyors

Type K1SH-160 and K1S-160 F

Manufacturer: Wolfgang Preinfalk GmbH

The gearboxes are dedicated for heavy belt conveyors with transferred power up to 500 kW at nominal speed 1470 r.p.m.

The gearboxes have an outlet for the brake wheel or for the equipment to prevent the reverse run.

The gearboxes are manufactured in the explosion-proof version.

Table of Transferred Power by Input Speed 1470 r.p.m.

| Gear Ratio i | Transferred Power in kW | | | | | | | | | | | |
|--------------|-------------------------|--------|--------|--------|--------|--------|--------|--------|--------|--------|--------|--------|
| | 15 : 1 | 16 : 1 | 17 : 1 | 19 : 1 | 21 : 1 | 24 : 1 | 25 : 1 | 28 : 1 | 31 : 1 | 33 : 1 | 39 : 1 | 45 : 1 |
| | | 160 | | 160 | 160 | | 160 | | 160 | | | |

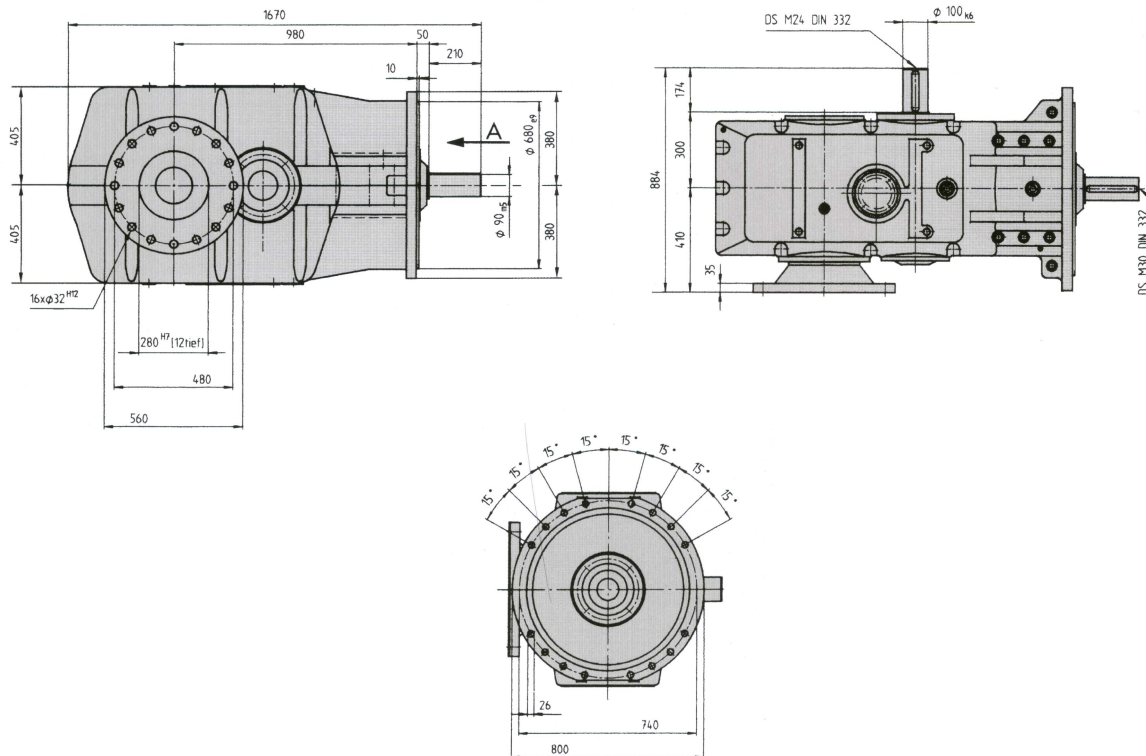

Technical Parameters:

| Gear Ratio | Maximum Torsion Moment | Output Revolutions | Speed of Belt v=m/s by the drum diameter | | | |
|------------|------------------------|--------------------|--|------|------|------|
| | Nm | r.p.m. | 500 | 630 | 800 | 1000 |
| 16 : 1 | 106 | 90.5 | 2.37 | 2.99 | 3.79 | 4.74 |
| 18 : 1 | 106 | 80.9 | 2.12 | 2.67 | 3.39 | 4.42 |
| 21 : 1 | 106 | 68.2 | 1.79 | 2.25 | 2.86 | 3.57 |
| 25 : 1 | 106 | 58.9 | 1.54 | 1.94 | 2.47 | 3.08 |
| 31.8 : 1 | 106 | 47.4 | 1.29 | 1.61 | 2.04 | 2.54 |