

Supporting Cover – Type NK

The supporting cover serves for the flange connection of the motor and the gear-box. It is adapted for use of the friction blocking appliance, the tightening device and eventually the brake. The supporting cover is manufactured in five versions and it is equipped with a flange for various types of devices – see the table below.

Marking	Version	D2	L	D1
		[mm]	[mm]	[mm]
NK600	P1	500	515	600
	P2	600	515	
	P3	740	545	
NK740	P1	600	515	740
	P3	740	545	

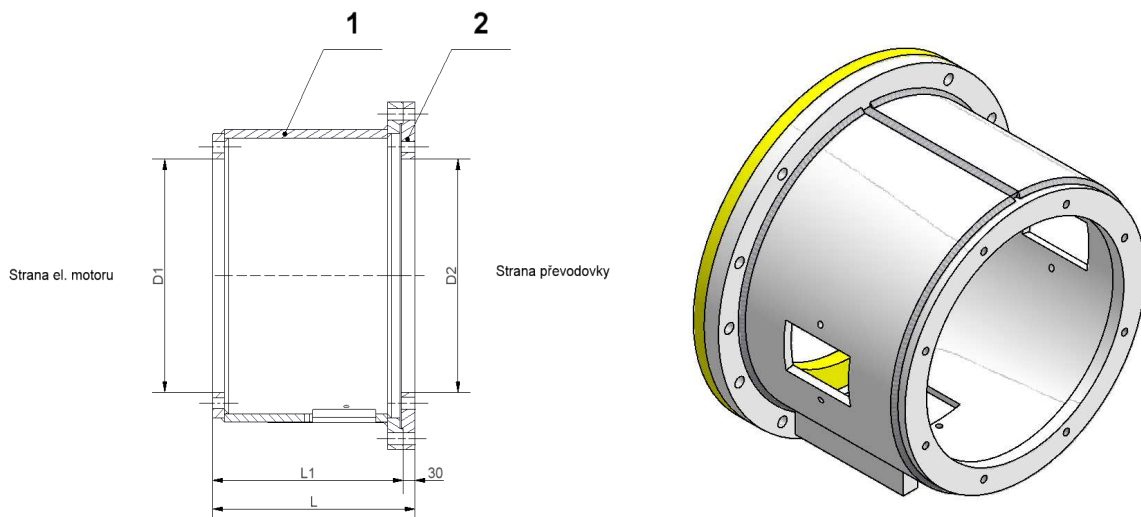

Item 1 – supporting cover

Item 2 – spacing flange for versions P1, P2

D1 – Ø electro-motor circle span

D2 – Ø gear-box circle span

L – total length of the supporting cover (including the spacing flange)

The versions P1 and P2 are always with the spacing flange

For the version P3: L1=L

Examples of the marking: NK600 P2, NK740 P3

In case of requirement for another design, it is necessary to inform us about the motor and the gear-box types and their connecting dimensions.